

A. LEFT/RIGHT CONFIGURATION

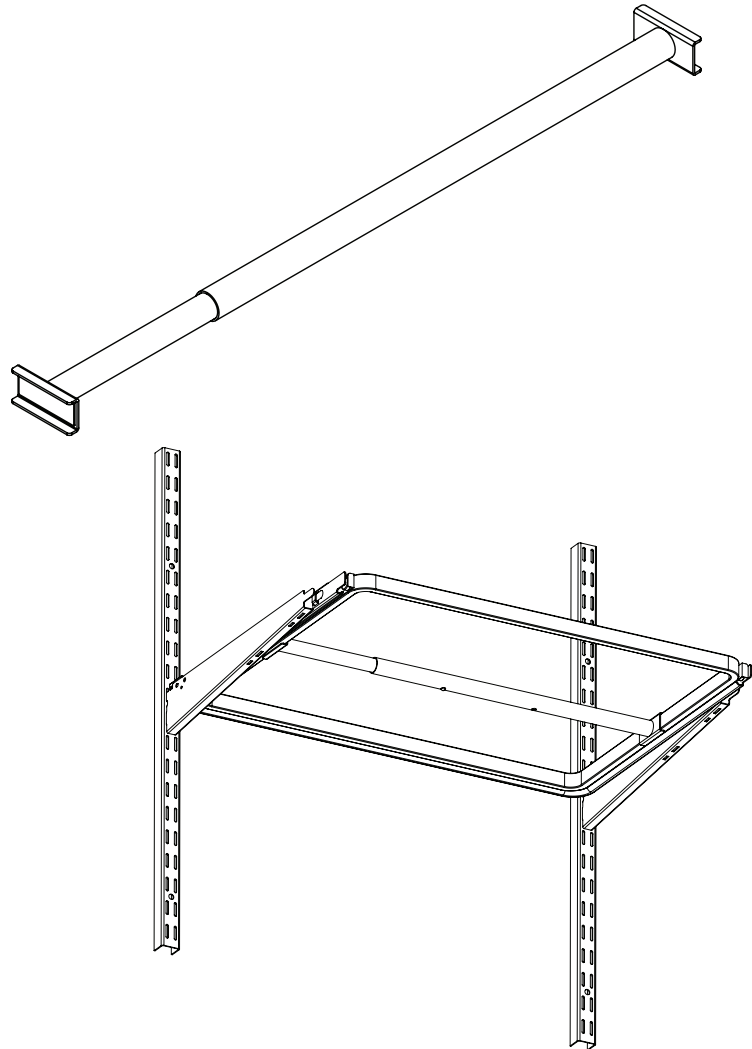

B. FRONT/BACK CONFIGURATION

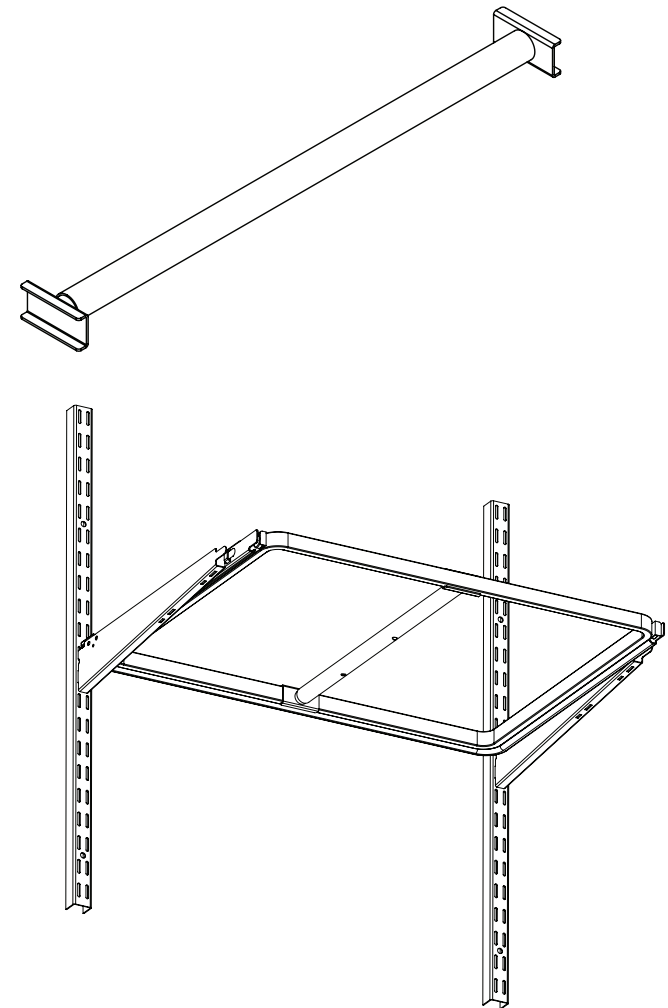

A. LEFT/RIGHT CONFIGURATION

STEP 1. A

Ensure hanging rod is the retracted position (as shown), by pressing the push button and retracting it until it clicks into the second hole.

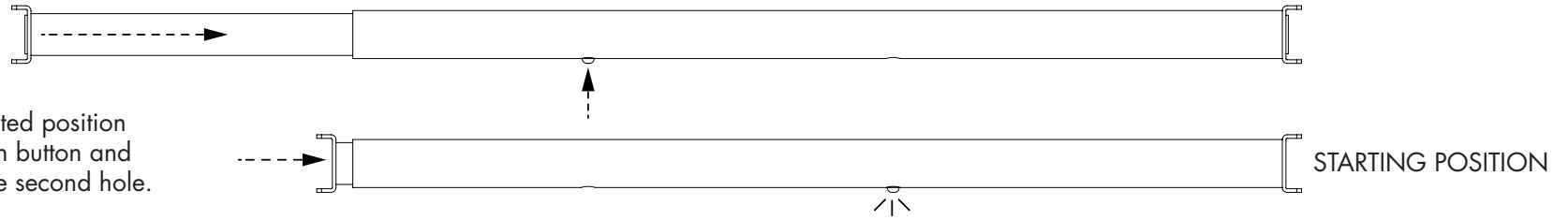

STEP 2. A

Attach one of the brackets to the inside of the sliding frame.

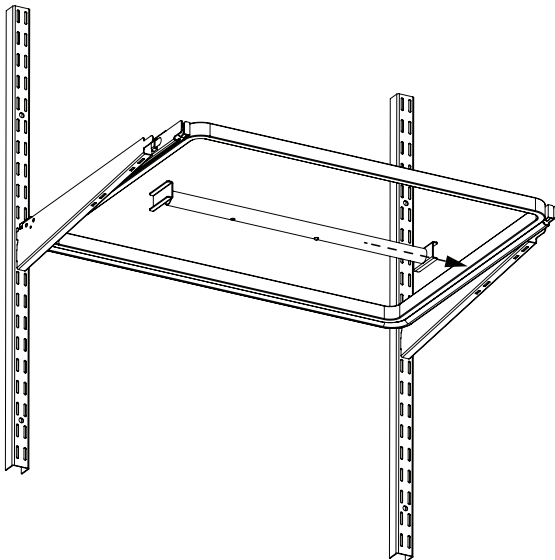

STEP 3. A

Press the push button and extend hanging rod to attach the second bracket to the inside of the sliding frame.

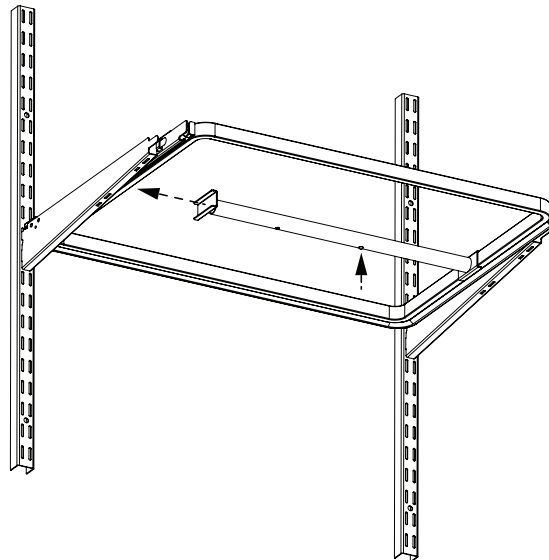

STEP 4. A

Firmly extend the rod until you hear the click of the push button.

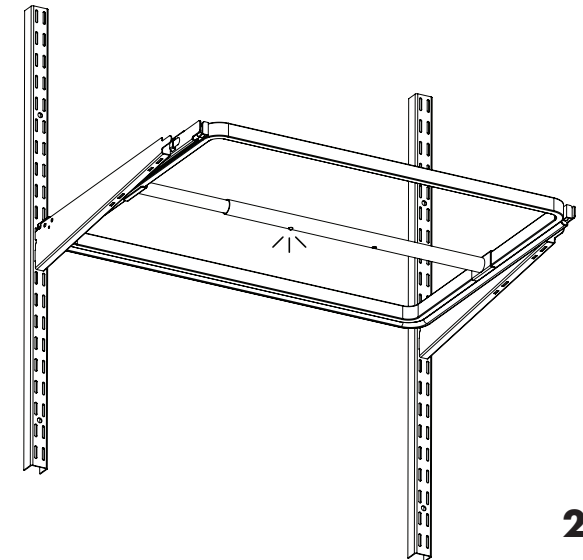

B. FRONT/BACK CONFIGURATION

STEP 1. B

Ensure hanging rod is in the fully retracted position (as shown), by pressing the push button and retracting it beyond the second hole.

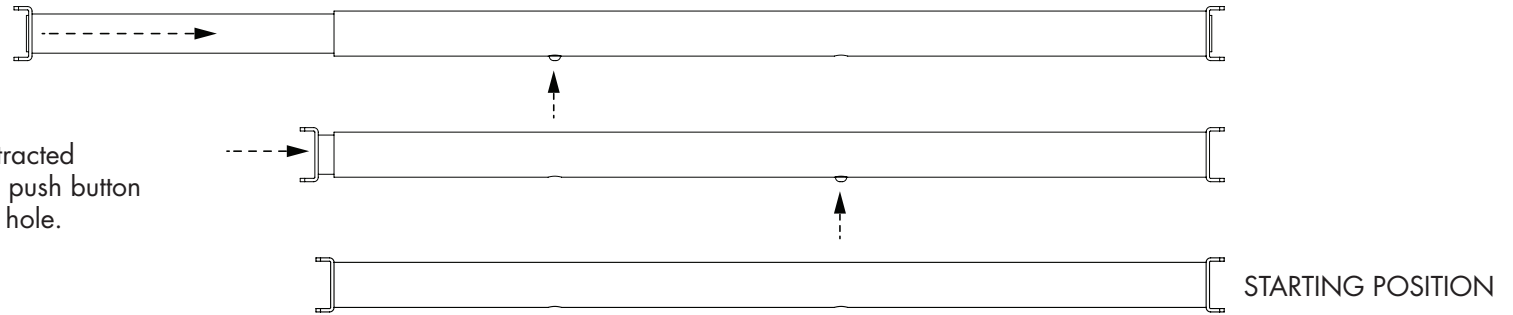

STEP 2. B

Attach one of the brackets to the inside of the sliding frame.

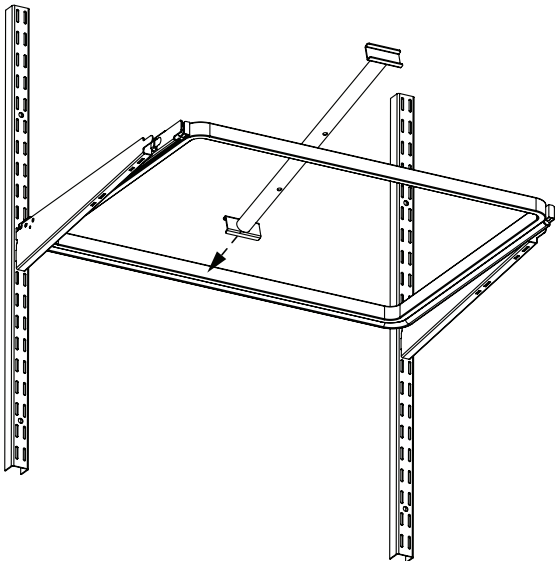

STEP 3. B

Extend the hanging rod to attach the second bracket to the inside of the sliding frame.

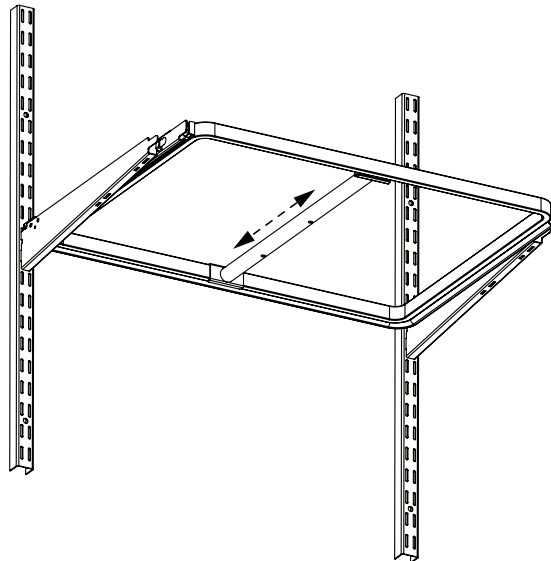

STEP 4. B

The rod is fully extended once the button has clicked.

