

**STEP 1**

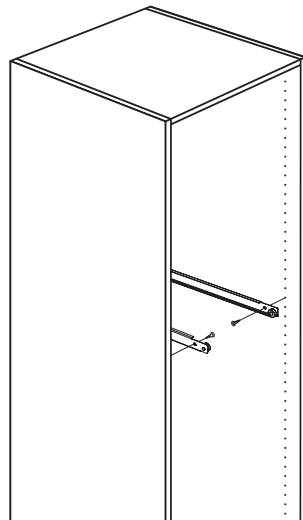

Fix Left and Right Runners so the Runner Wheel is positioned at the front of the cabinet. Make sure they are located at the same height  
**Hint:** Count the pre-drilled holes from the top or bottom of cabinet so both runners are level.

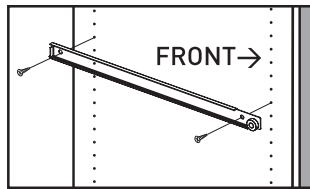

**STEP 2**

Insert Shoe Rack into the Runners. Tilt Shoe Rack so the wheel on the FRONT of the Shoe Rack fits into the gap in front of the Runner wheel. The Shoe Rack should run freely.

