

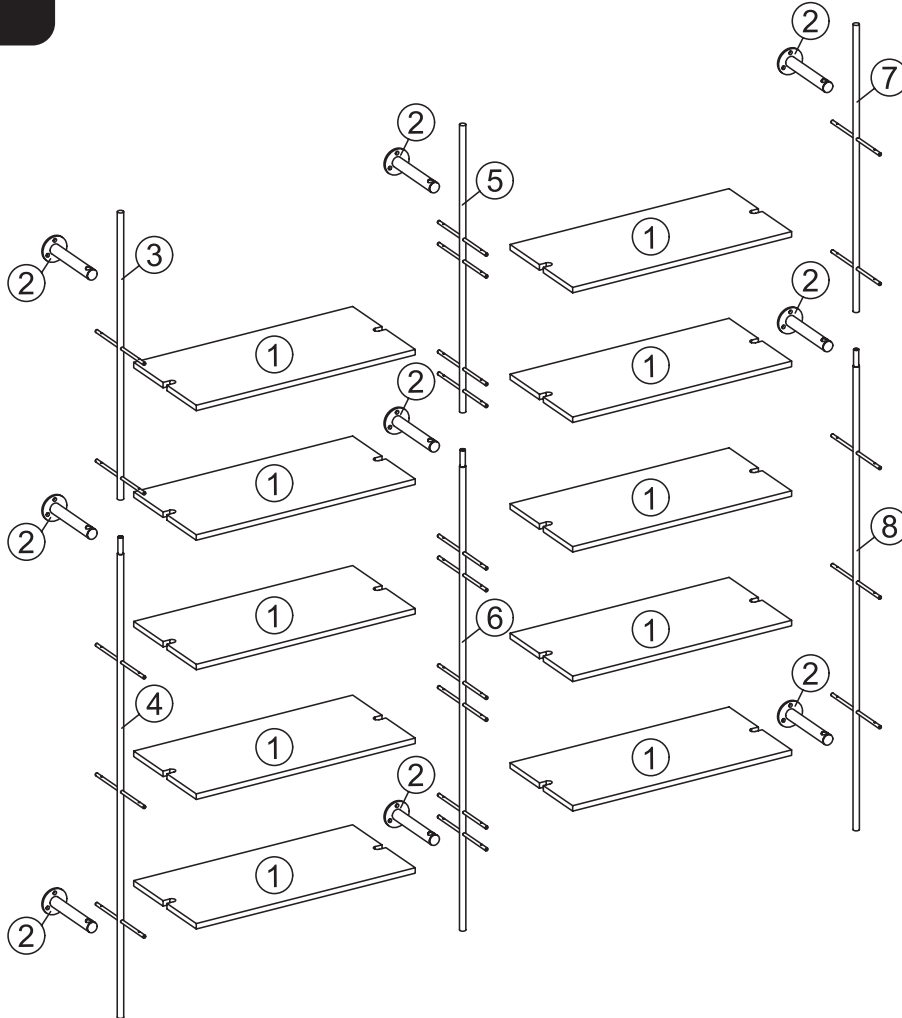





Care Instructions: We recommend to wipe over with a dry micro-fibre cloth to remove dust. Avoid using a damp or wet cloth and any cleaning chemicals as this may cause damage to the surface.

ELEMENTS

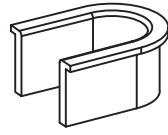

HARDWARE

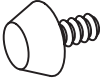
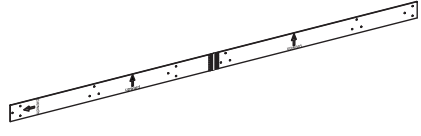
<p>A</p>  <p>x40</p>	<p>B</p>  <p>x27</p>	<p>C</p>  <p>x27</p>	<p>D</p>  <p>x27</p>	<p>E</p>  <p>x20</p>
<p>F</p>  <p>x3</p>	<p>G</p>  <p>x1</p>	<p>H</p>  <p>x3</p>	<p>I</p>  <p>x1</p>	

STEP 1



Ensure the end holes in 4 and 3 align.

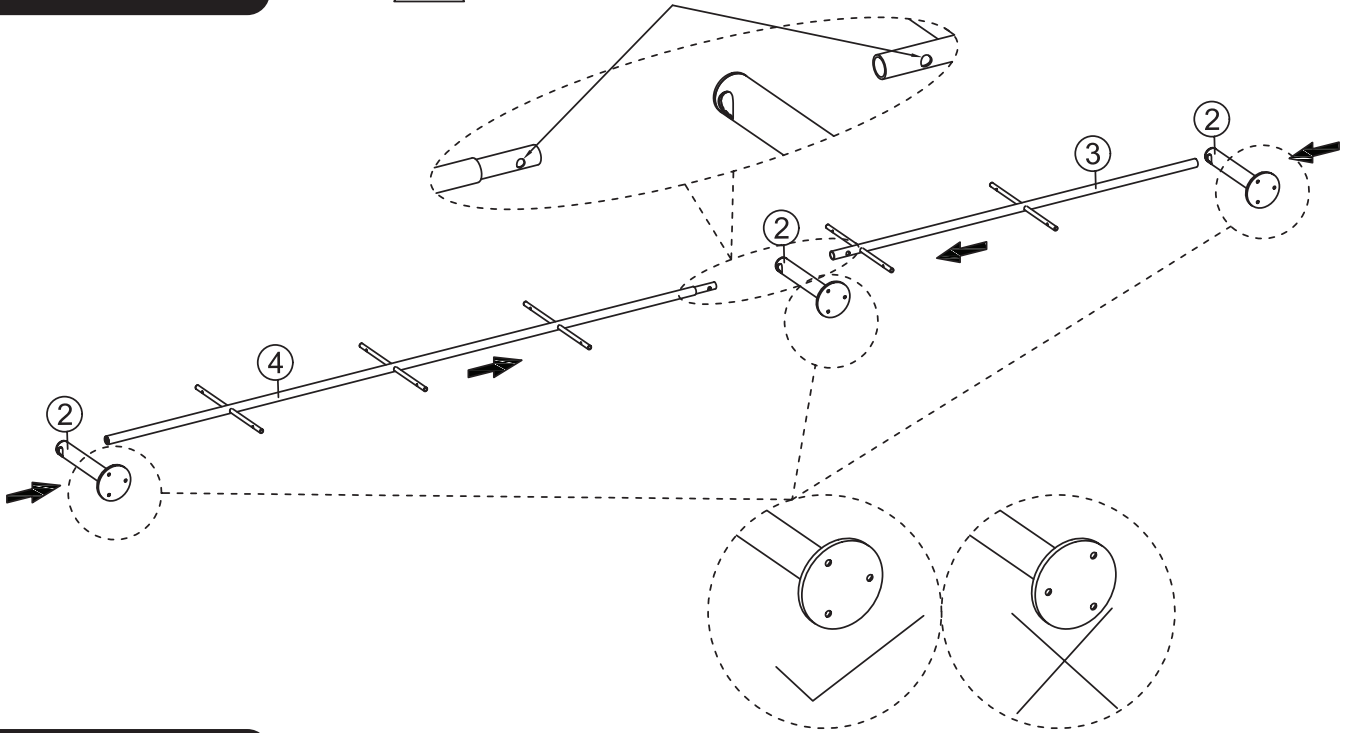

STEP 2

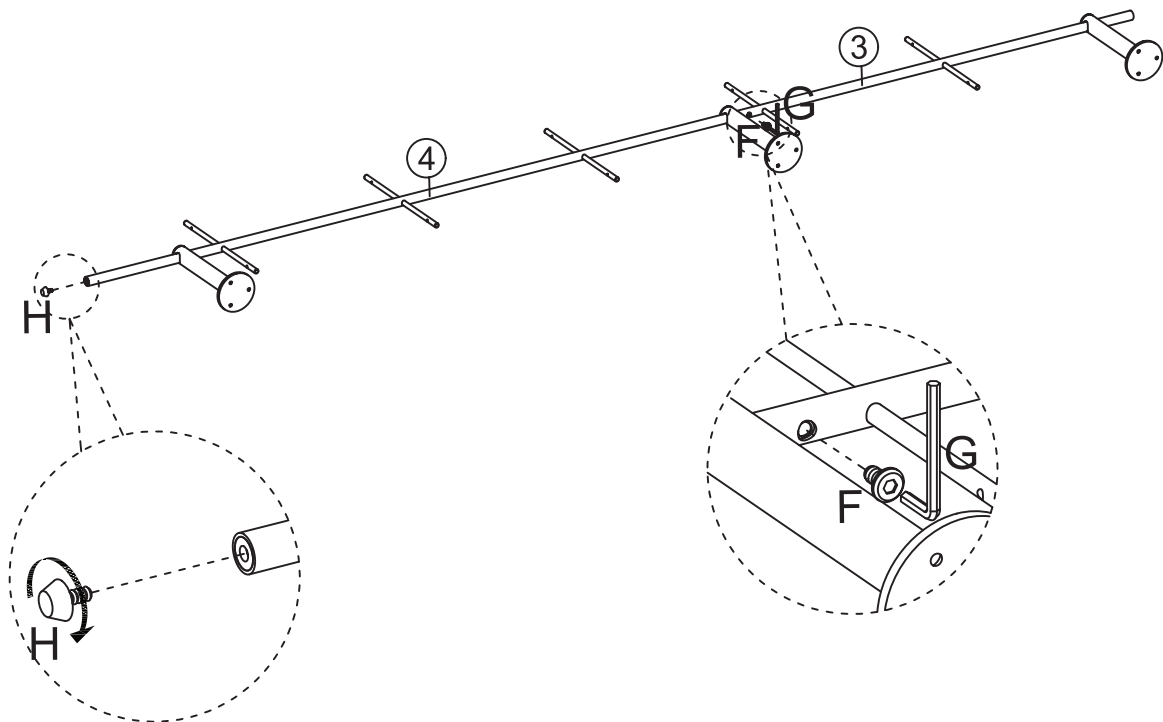

STEP 3



Ensure the end holes in 8 and 7 align.

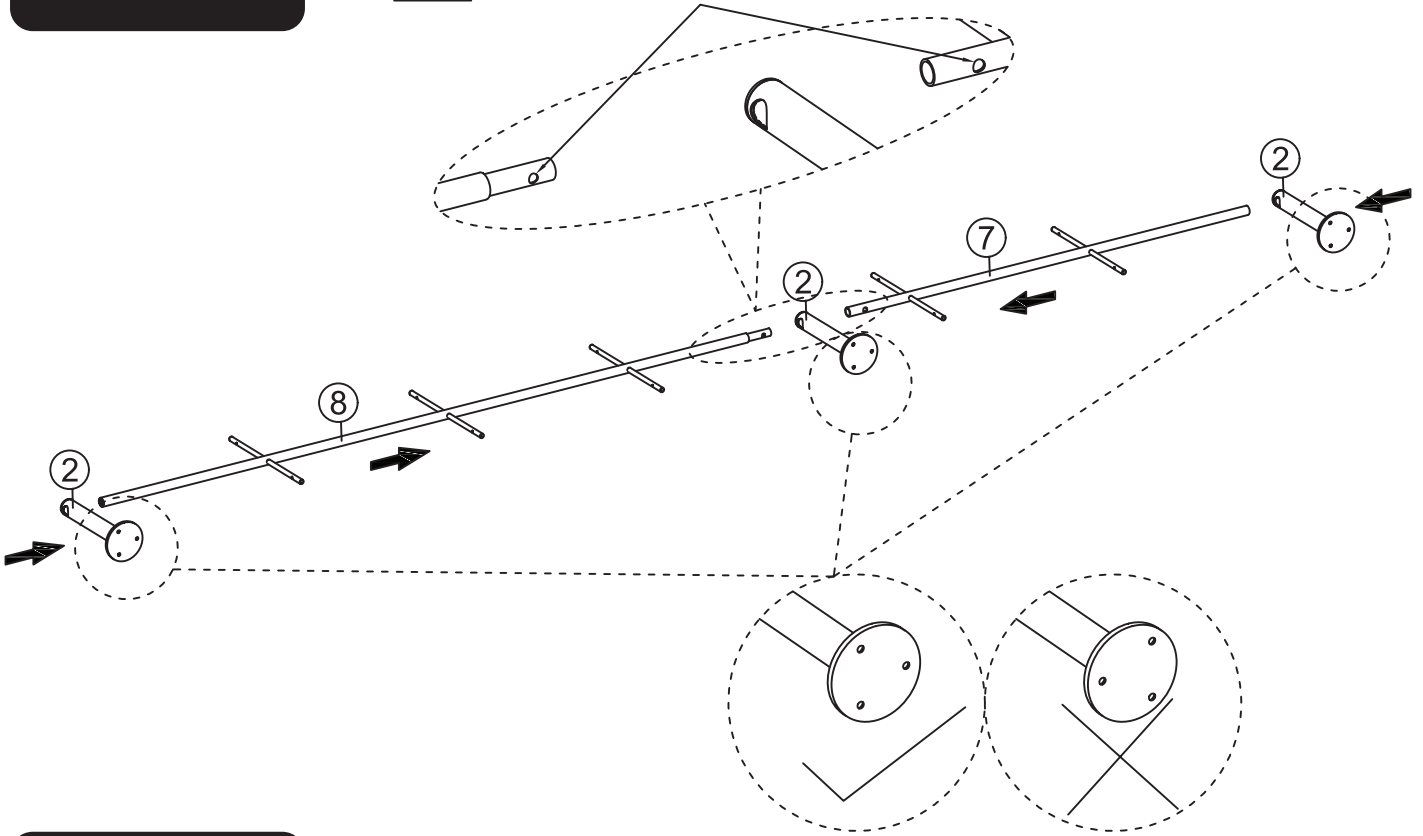

STEP 4

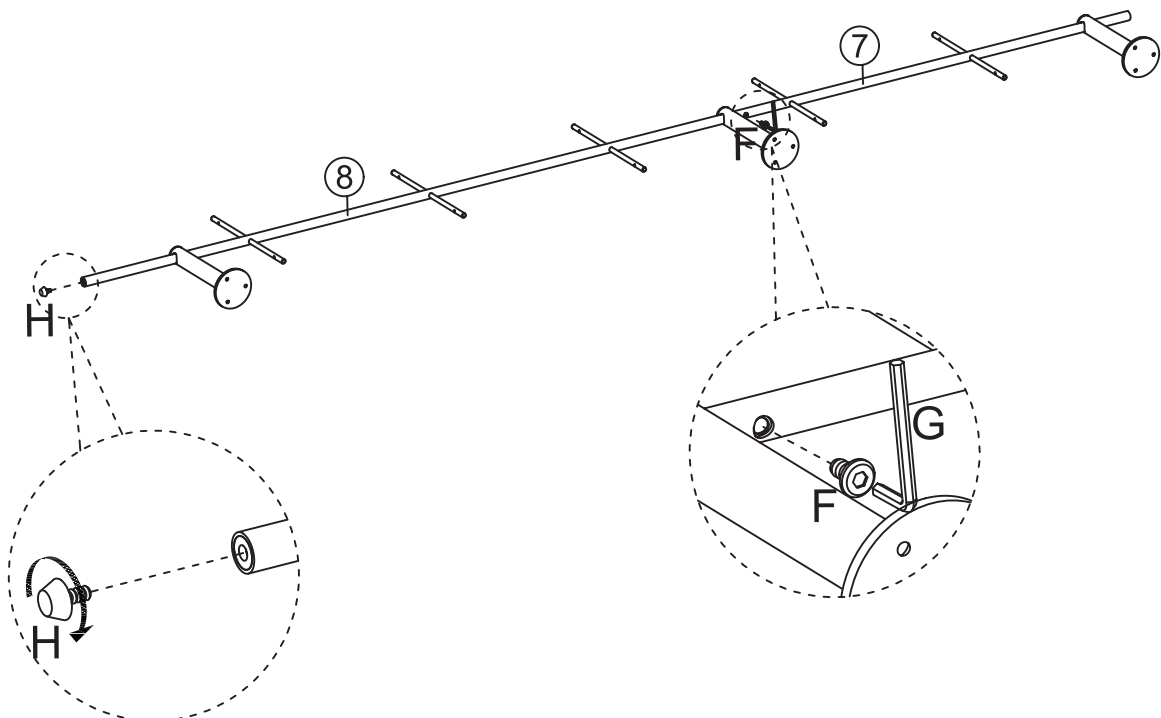

STEP 5



Ensure the end holes in 6 and 5 align.

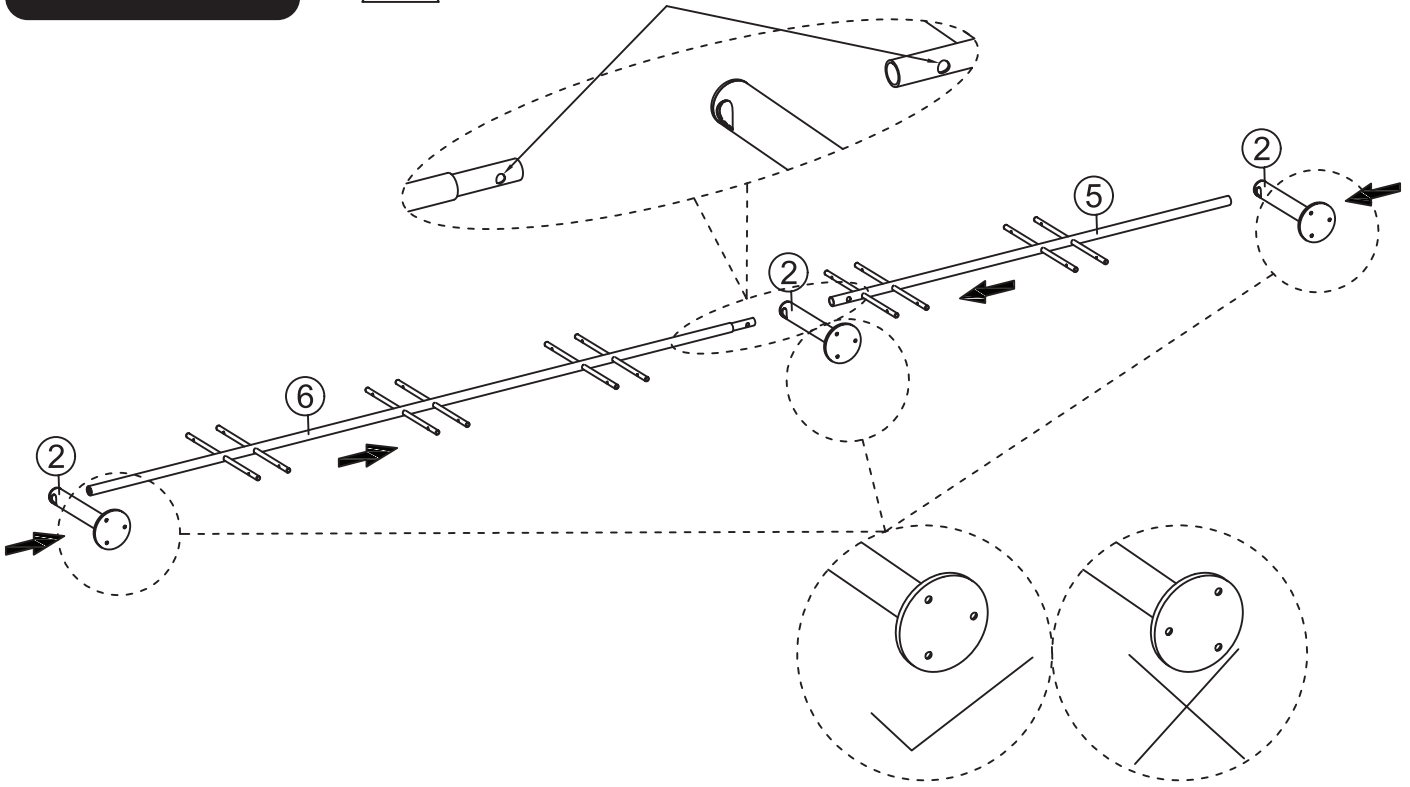

STEP 6

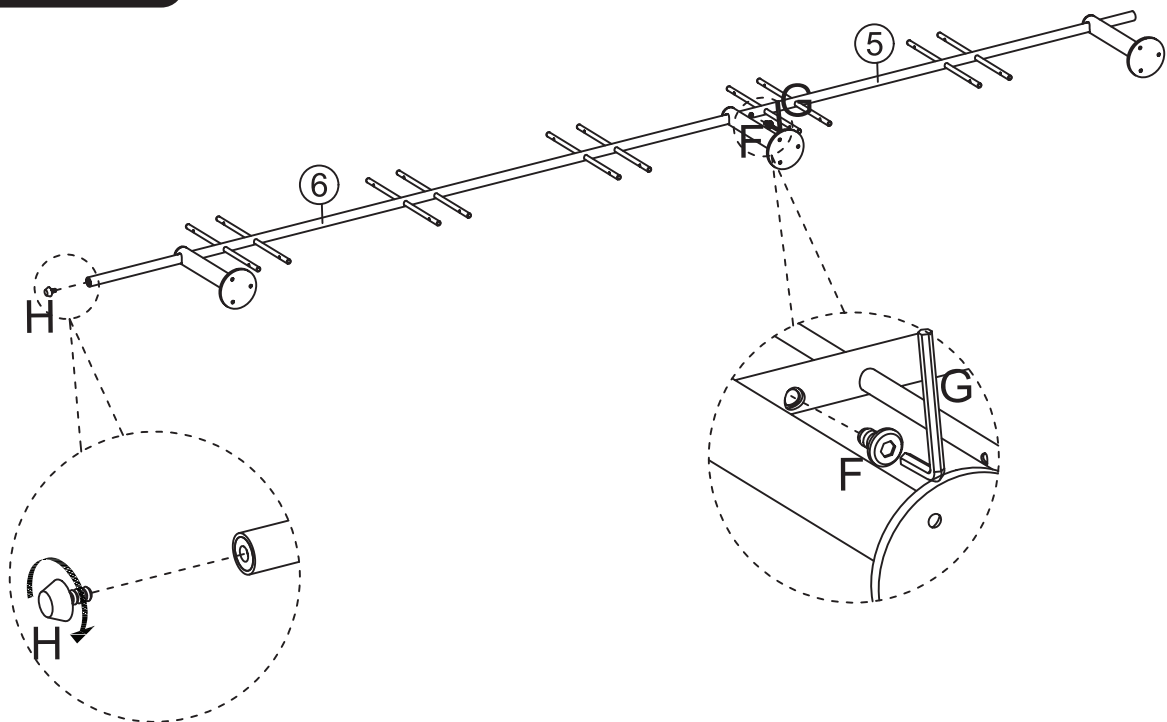

STEP 7

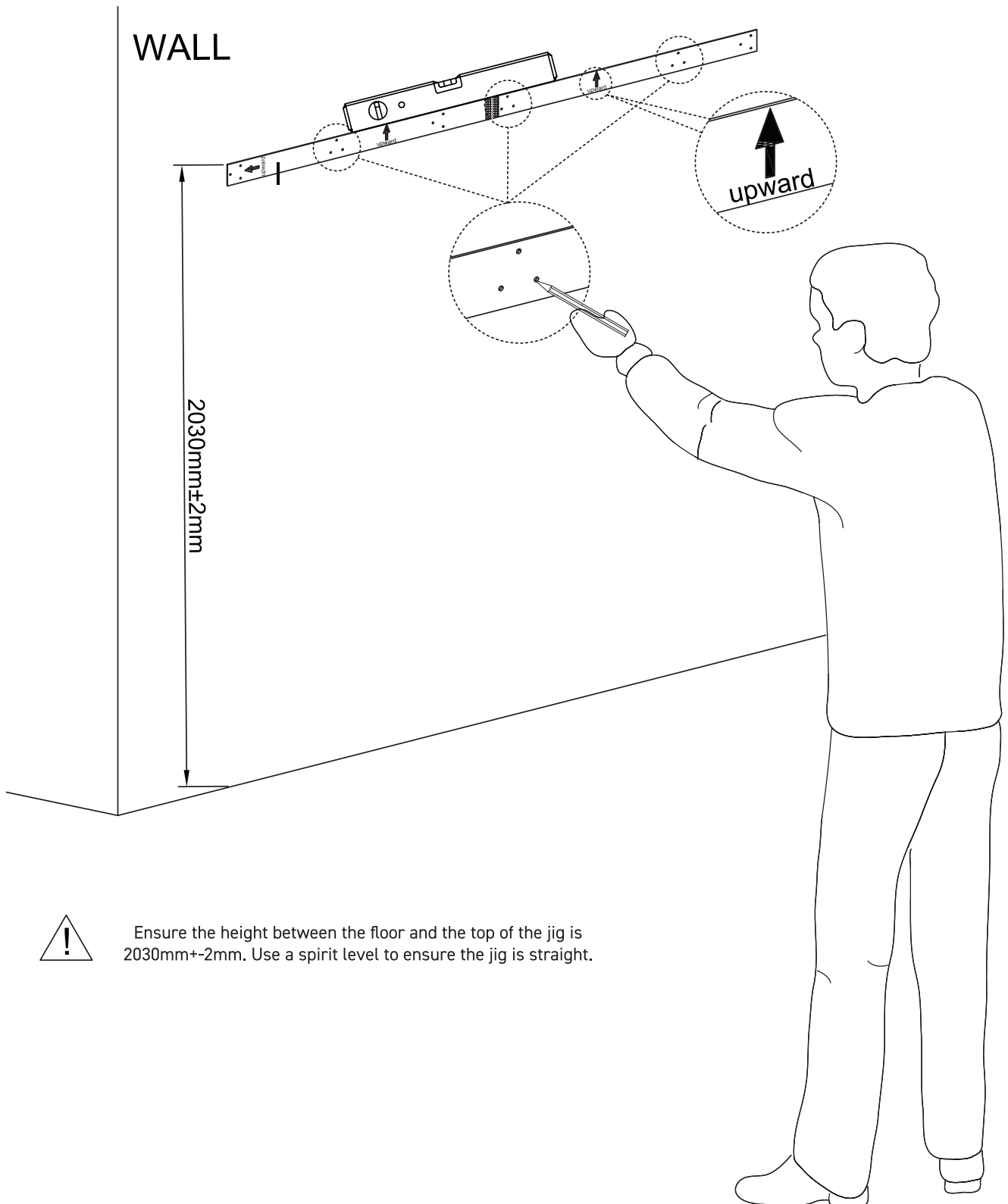

Ensure the height between the floor and the top of the jig is 2030mm±2mm. Use a spirit level to ensure the jig is straight.

STEP 8

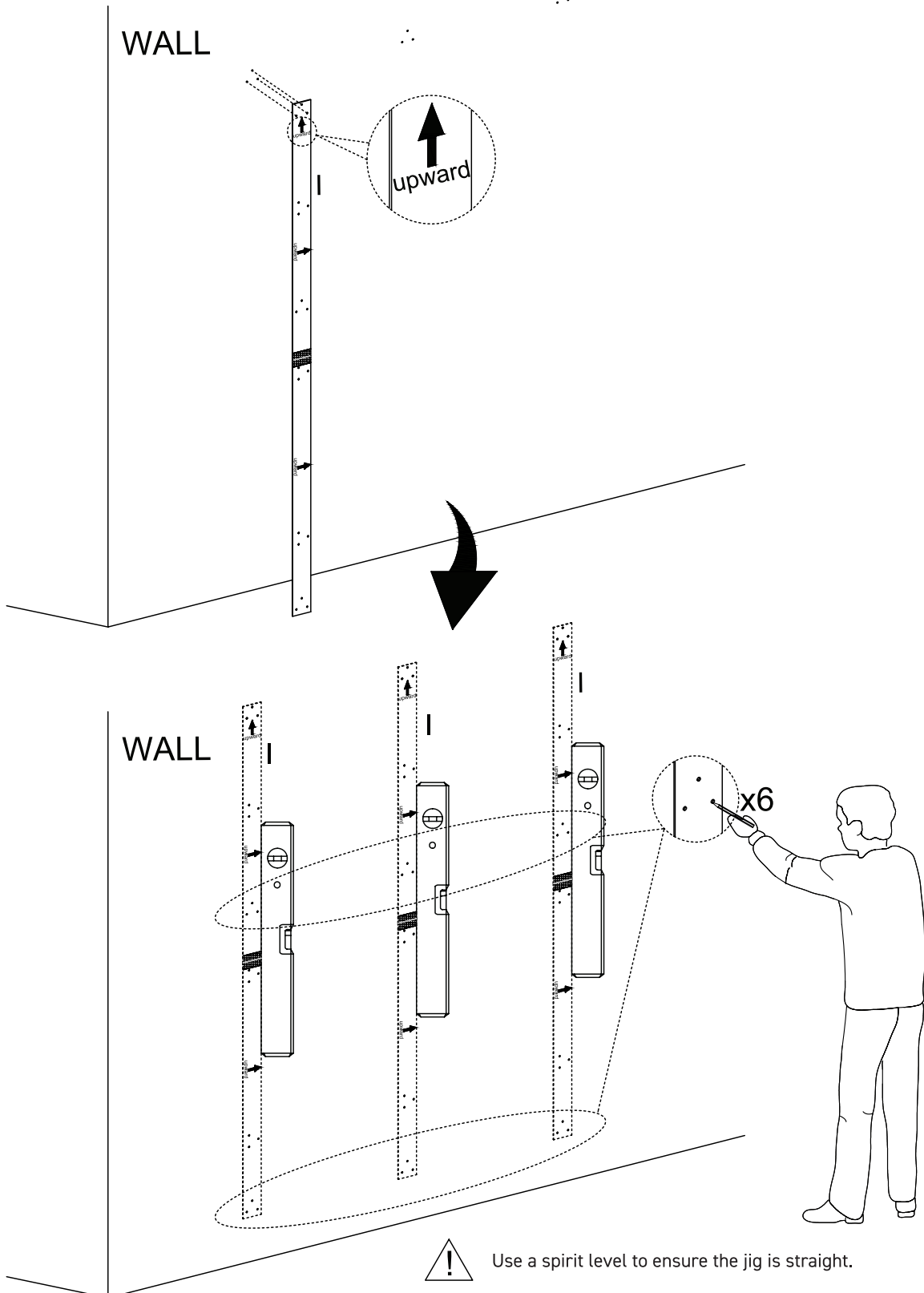

STEP 9

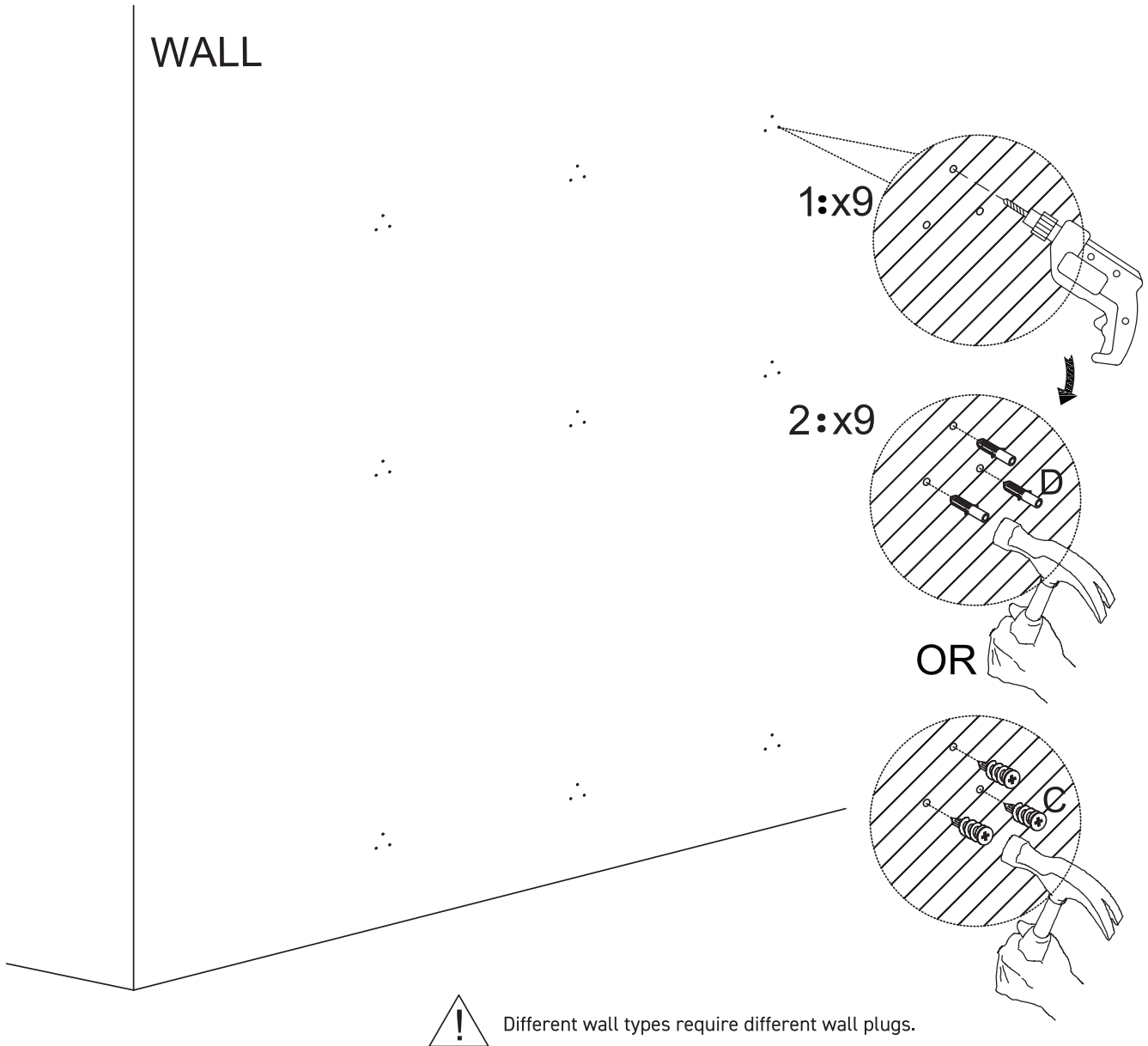

STEP 10

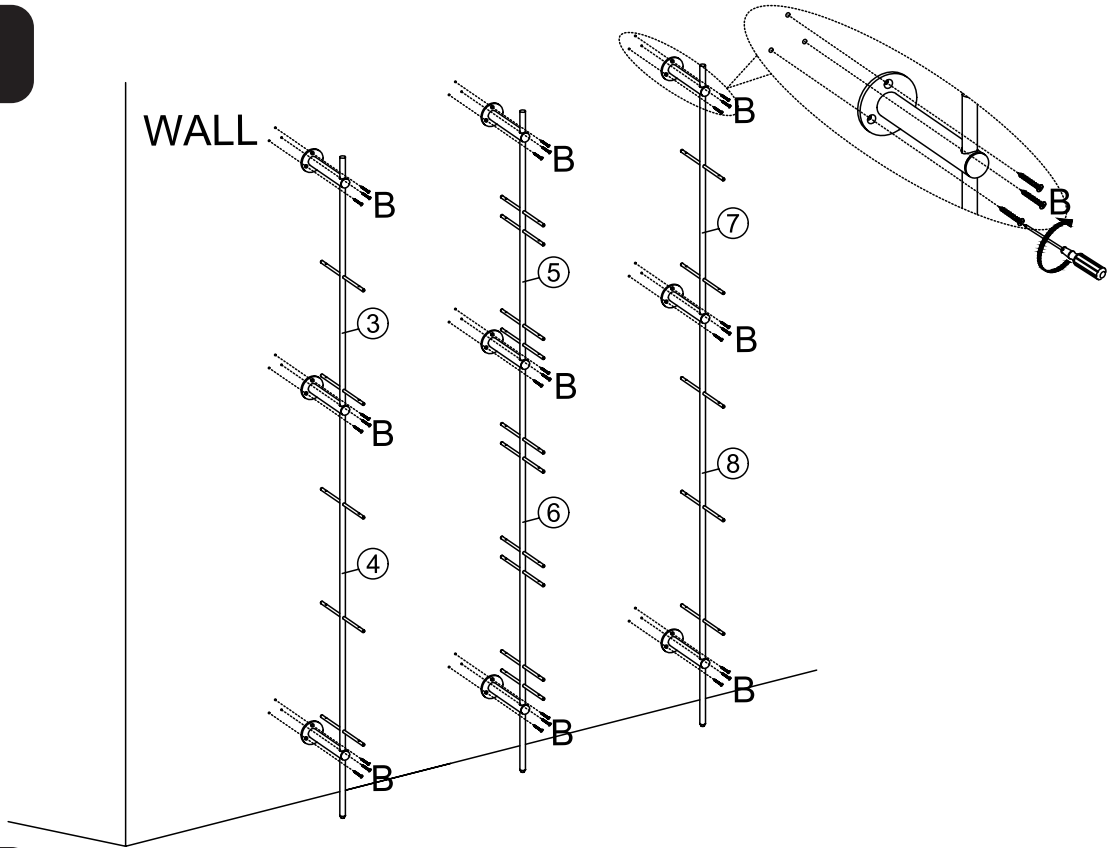

STEP 11

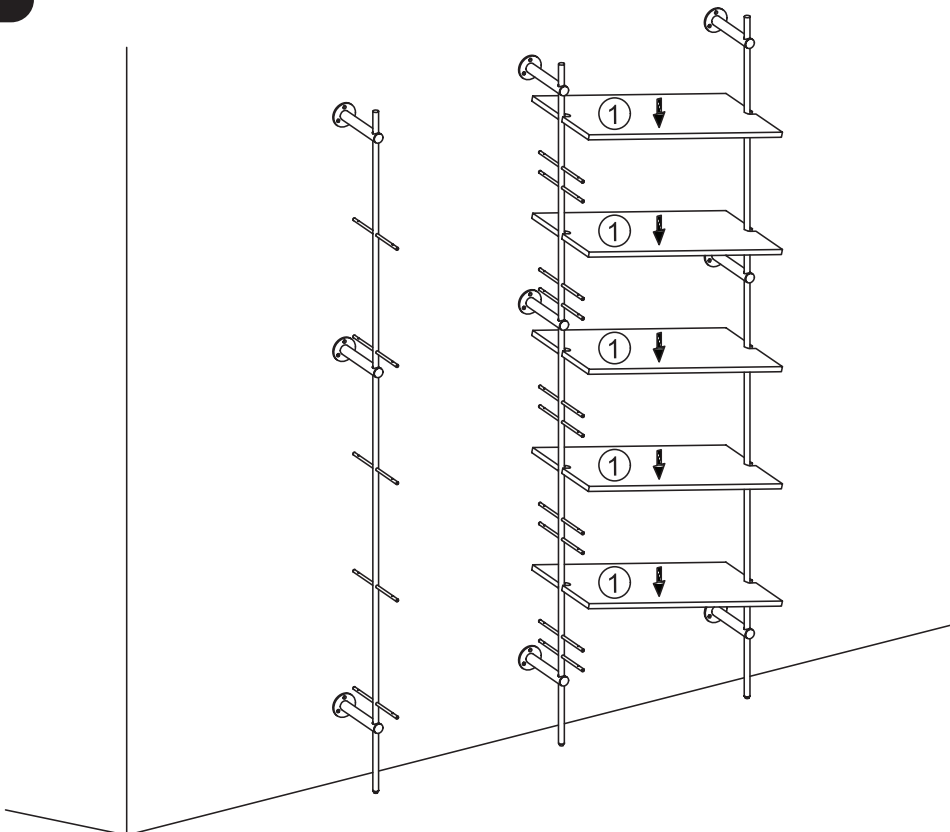

STEP 12

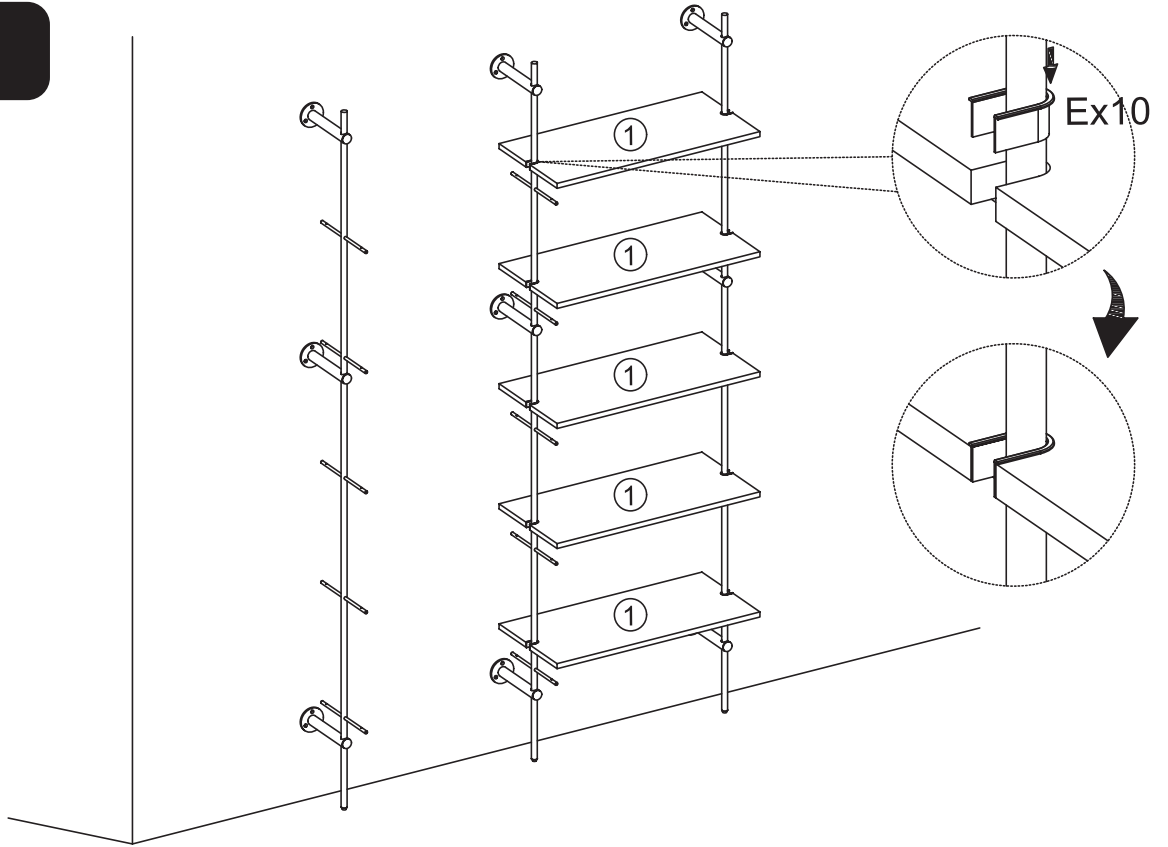

STEP 13

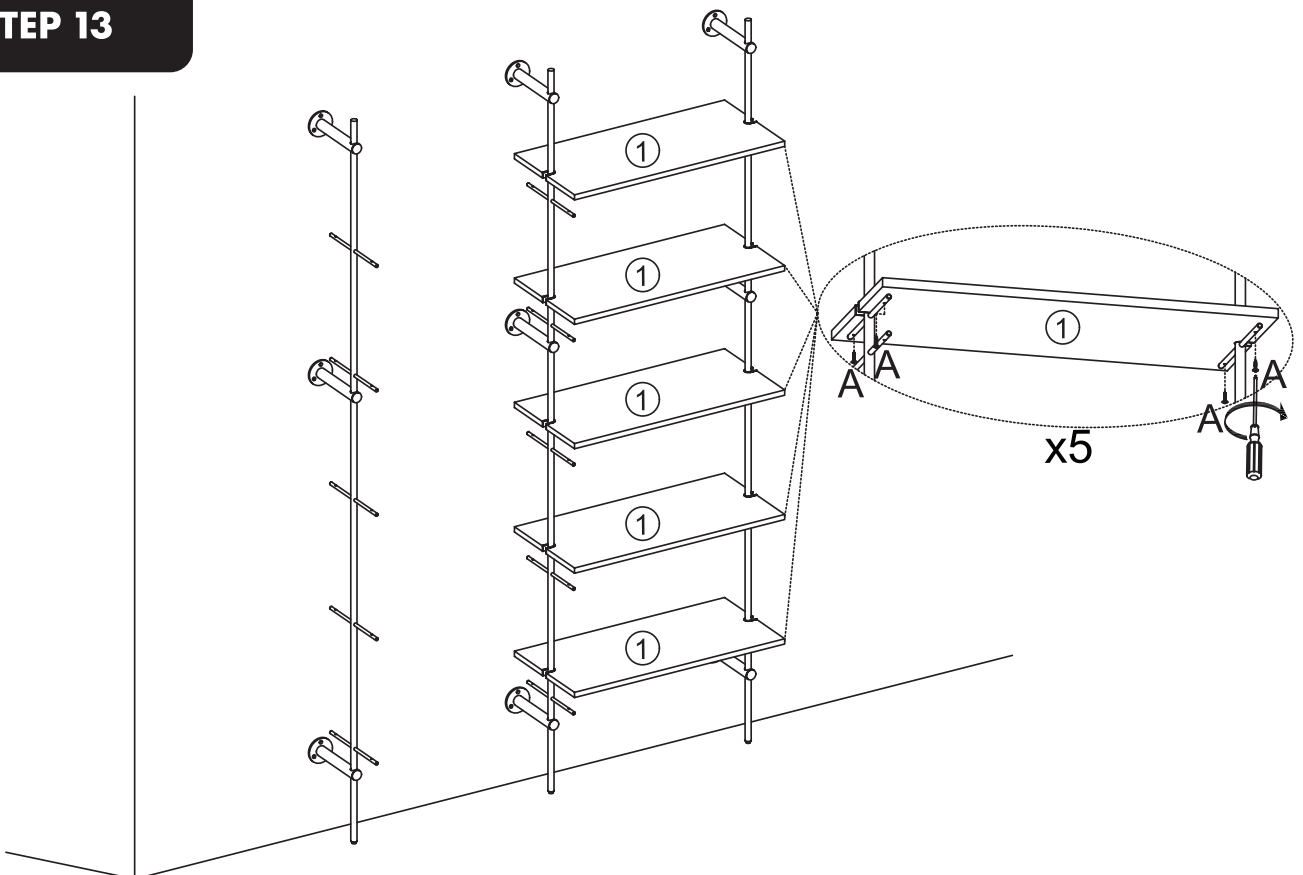

STEP 14

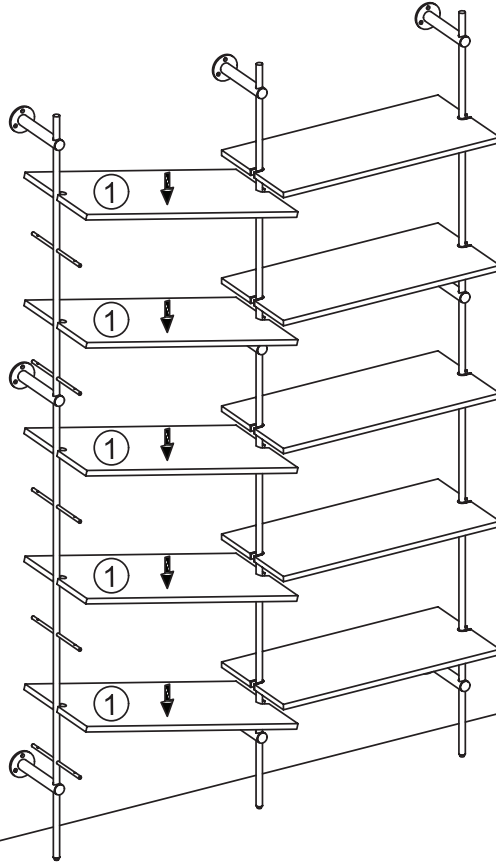

STEP 15

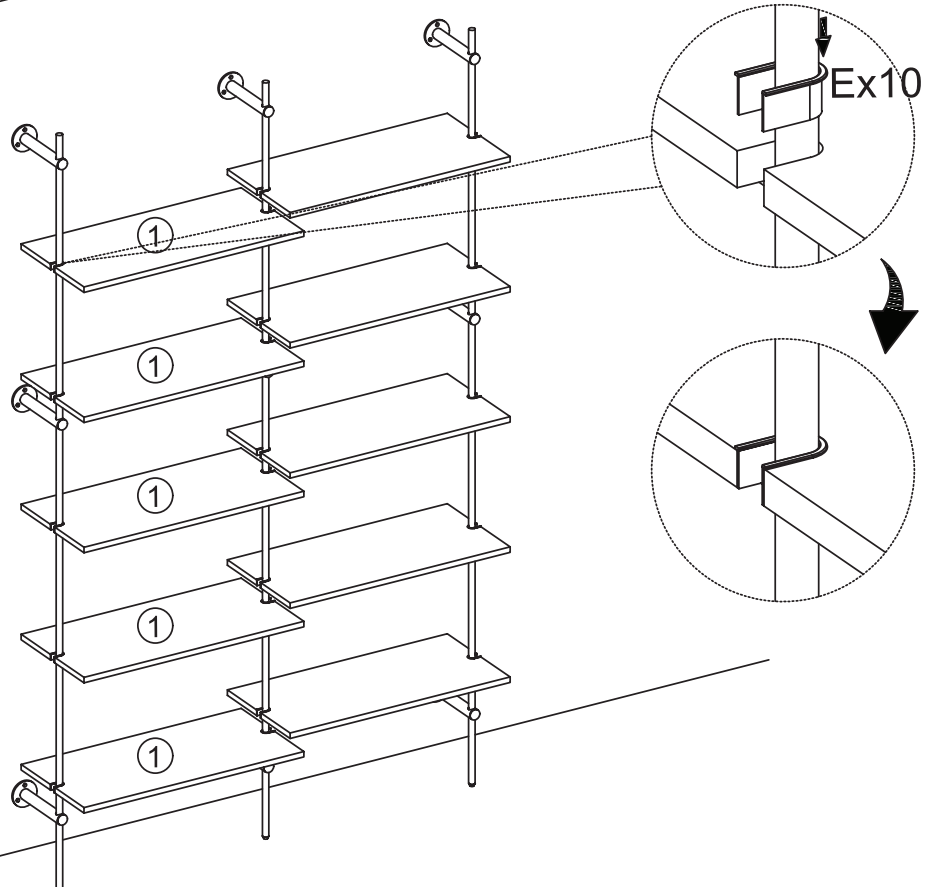

STEP 16

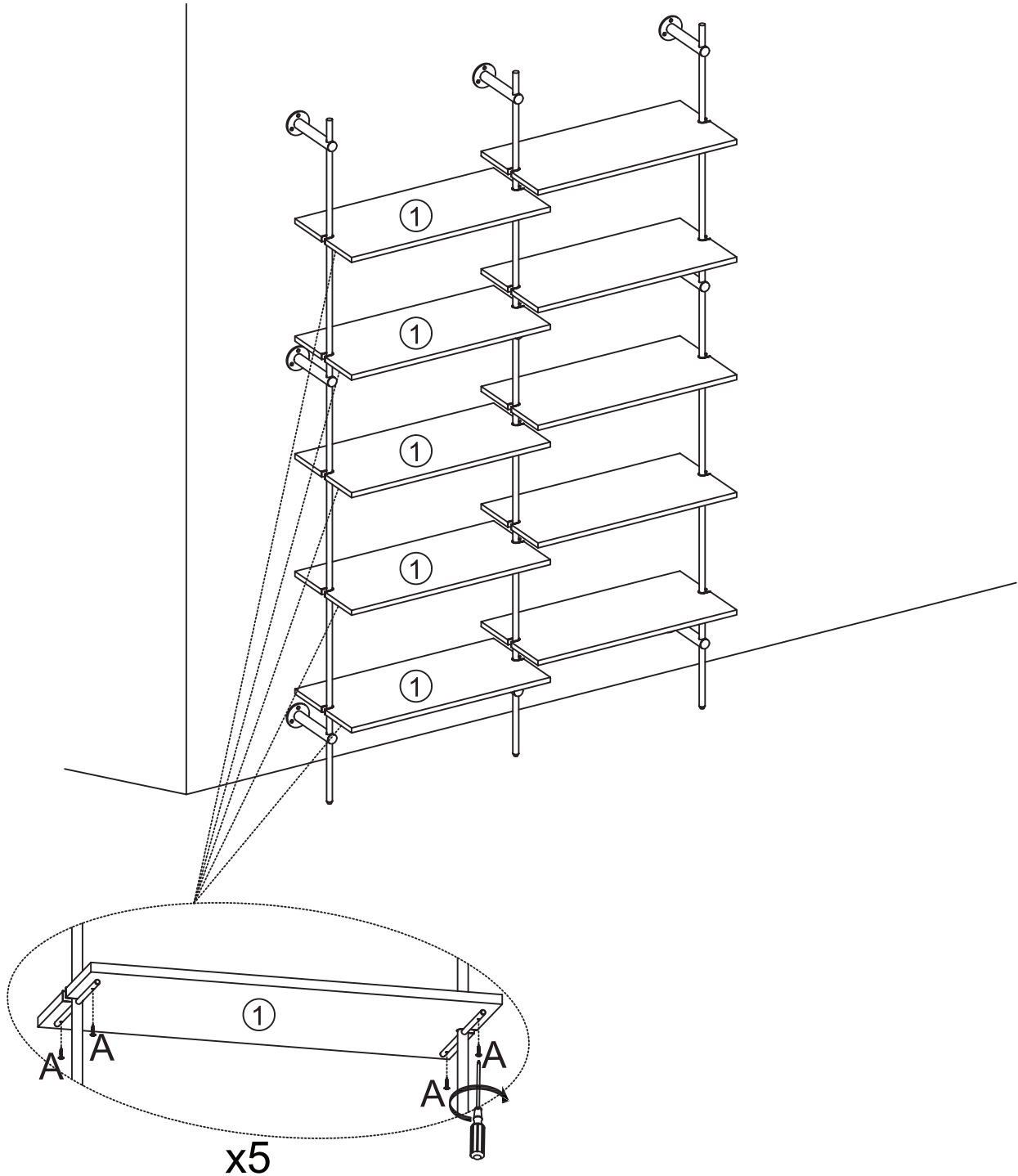

MADE IN CHINA
Distributed by:
Zenexus (AUS) Ph: 1300 734 714
Zenexus (NZ) Ph: 0800 443 058

flexistorage.com.au
flexistorage.co.nz